

Features and Benefits



UK
CA CE

- 💧 User-configurable display of dewpoint in °C or °F dewpoint, ppm(v), g/m³ or lb/MMSCF, factory pre-configured to customer order
- 💧 Linear 0-20/4-20 mA isolated retransmission signal
- 💧 2 programmable alarm relays
- 💧 4 digit display
- 💧 Front panel protection to IP65 / NEMA 4X
- 💧 Exd option for installation in Ex Hazardous areas. Flameproof to ATEX and IECEx Certification for use in potentially explosive atmospheres

For continuous trace moisture measurement in gases and dry compressed air and dry rooms/chambers. The DS1200 Dewpoint Hygrometer is installed in the safe area (non-hazardous), and is a panel mounted single-channel Indicator specifically designed to work with Alpha Moisture Systems Online Dewpoint Transmitters AMT and PDT transmitter (Safe area use), and the AMT-Ex transmitter (where the transmitter only is installed in the hazardous area).

The DS1200 can be factory configured to read in °C dewpoint, °F dewpoint, ppm(v), ppb(v), g/m³ or lbs/MMSCF. The measured value is displayed on a large four-digit LED display.

The Indicator offers a selectable 0-20 mA or 4-20 mA isolated retransmission signal and two programmable alarm relays, which can be independently set across the operating range of the Transmitter.

The DS1200 is our entry-level Indicator, offering simplicity and functionality for most routine applications. Our fully-featured DS4000 will satisfy more advanced applications requiring a user-configurable display and greater versatility.



DS1200 Technical Data

Power Supply	22Vac - 253Vac 50/60Hz & 20Vdc -300Vdc
Output Signal	Linear 0-20/4-20 mA isolated retransmission signal
Alarm Relays	2 programmable alarm relays. Contacts rated 2A @ 250Vac / 1A @ 24Vdc.
Power Consumption	3.5 W Maximum
Electromagnetic Compatibility (EMC)	Complies with BS EN IEC 61326-1
Operating Temperature (Ambient)	-20 °C to +60 °C
Operating Humidity (Ambient)	Maximum 95 %RH Non-Condensing
Cut-out Dimensions	44.5 mm x 91.5 mm
Weight	230 g
Dimensions	Height 48 mm, Width 96 mm, Depth 120 mm
Ingress Protection	Front panel only IP65 / NEMA 4X
Manufacturers Warranty	12 months in case of defective parts or faulty workmanship

FRONT

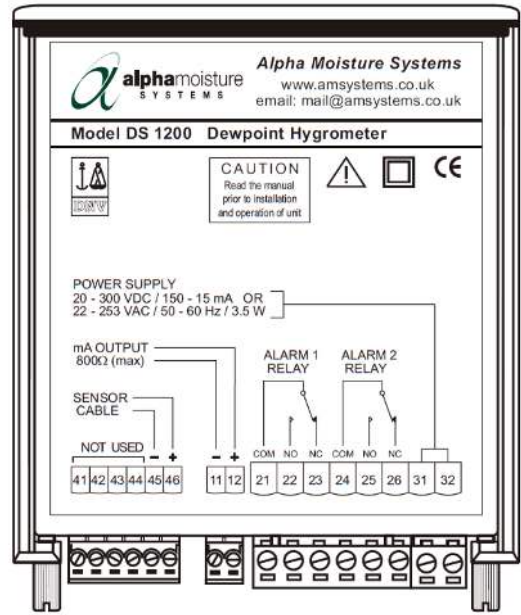
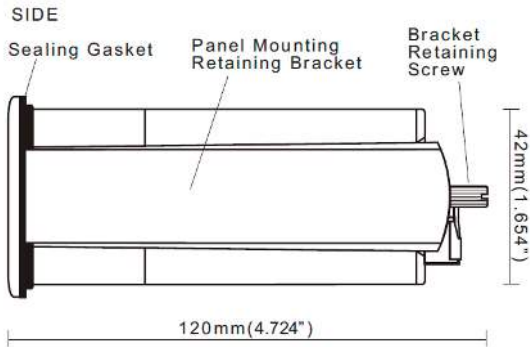
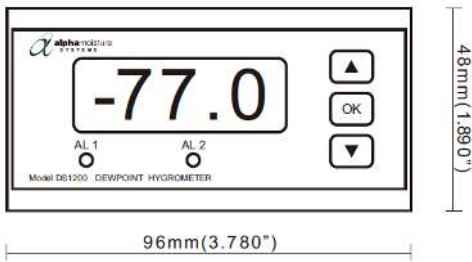

How to Order

DS1200 - [X]

Specify input range:

- [A] -4-20mA
- [B] -0-20mA

Related Products

The Dewpoint Transmitters and Isolator below are fully compatible with the DS1200 Dewpoint Hygrometer



AMT-Ex
For Hazardous Applications



Isolator
Used with AMT-Ex. Isolator and DS1200 in the safe area



AMT
Used with DS1200 in the Safe area



PDT
Used with DS1200 in the Safe area

Corrosive Gases: The Sensor should not be exposed to corrosive gases (or corrosive contaminants in the gas sample) as these can chemically attack the sensor, impairing calibration accuracy and/or damaging it beyond economic repair. Examples of such gases are mercury (Hg), ammonia (NH₃), chlorine (Cl₂) etc. Strong oxidising agents such as ozone (O₃) should also be prevented from coming into contact with the sensor.

3038 DS1200 pd200923-Iss-2

Alpha Moisture Systems Limited.
Registered Office: Alpha House,
96 City Road, Bradford, BD8 8ES. UK.



Product specification may be subject to change.

Registered in England and Wales No. 3902302
VAT Registration No. GB607207563
WEEE Producer Registration No. WEEE/EA0067TX

© Alpha Moisture Systems Ltd.

Tel	+44 (0) 1274 733100
Email	info@amsystems.co.uk
Website	www.amsystems.co.uk